

MODEL 79 FULL-FUNCTION WELD HEADS

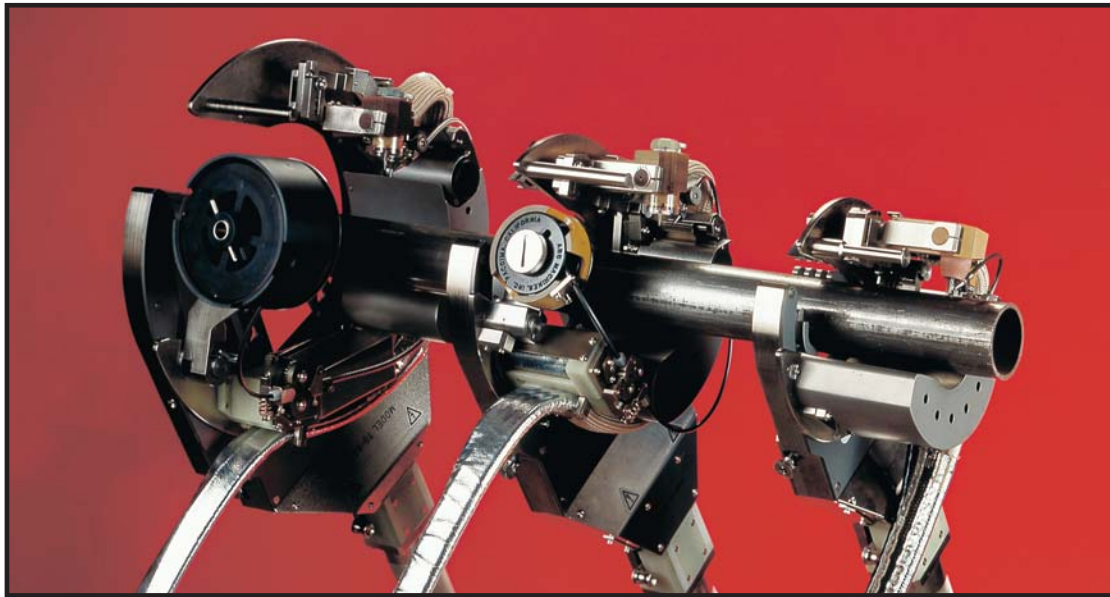

The Model 79 series of high durable "full function" weld heads are specifically designed for fabrication shop and field process pipe welding applications. Model 79 weld heads have a unique integral clamping system which gives each weld head the ability to adjust for different pipe and tubing diameters in seconds, thereby eliminating the requirement for specific sized guide rings and saving both time and money. Each Model 79 in the series offers programmable control of welding current, arc voltage (AVC), oscillator (torch weaving), travel speed, wire feed speed and includes a water cooled torch 100% duty cycle operation.

The Model 79 series is compatible with a variety of joint designs such as 'J' prep and square butt, and will weld materials ranging from stainless or carbon steels to exotic alloys such as Hastelloy,[™] Inconel,[™] and Monel,[™] as well as all other TIG weldable materials. The Model 79's use the same "self centering" clamping mechanism and drive housing as the Model 95 series and mount on any pipe or tube diameter within its range with only a simple adjustment to the clamp. Precision-machined clamping jaws always hold the weld head concentric to the pipe, within $\pm 0.010"$. Model 79 weld heads are ideal for pipe shop applications as well as for in-place on-site use in a variety of industrial piping environments. The Model 79 series is compatible with AMI Model 215, 227 or 415 power supplies.

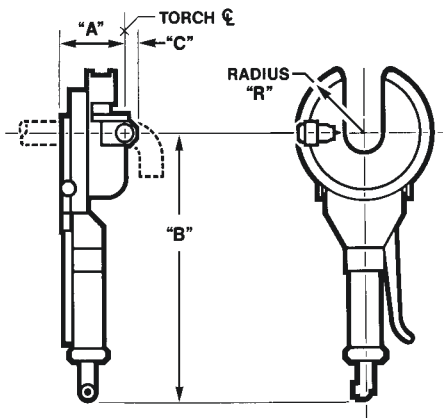

Weld Head Model #	Tube / Pipe O.D. Range	Dimensions			
		A	B	C	R
79-2375	0.75" - 2.375" 19mm - 61mm	4.50" * 114mm	16.25" 413mm	0.63" 16mm	3.43" 87mm
79-3500	1.00" - 3.50" 25mm - 90mm	4.50" * 114mm	19.25" 490mm	0.63" 16mm	4.25" 108mm
79-4500	1.90" - 4.50" 48mm - 114mm	4.50" * 114mm	19.25" 490mm	0.63" 16mm	5.25" 133mm
79-6625	2.00" - 6.625" 50mm - 170mm	4.50" * 114mm	19.25" 490mm	0.63" 16mm	6.31" 160mm

* with cross-seam "in" all the way

Specification subject to change without notice.

MODEL 79 FULL-FUNCTION WELD HEADS



MODEL 79-2375



MODEL 79-3500



MODEL 79-4500



MODEL 79-6625

Tube/Pipe O.D.	0.75" - 2.375" 19mm - 61 mm	1.00" - 3.50" 25mm - 90mm	1.90" - 4.50" 48mm - 114mm	2.00" - 6.625" 50mm - 170mm
Torch: (water-cooled)	200 amp continuous duty cycle	200 amp continuous duty cycle	200 amp continuous duty cycle	200 amp continuous duty cycle
Rotation Speed:	0.1 - 5.0 RPM	0.05 - 2.0 RPM	0.05 - 2.0 RPM	0.05 - 2.0 RPM
Wall Thickness:	up to 0.44"	up to 0.44"	up to 0.675"	up to 0.75"
Torch Adjustments: lead / lag cross-seam tilt in / tilt out	± 5° ± 0.25" 15° / 45°	± 10° ± 0.375" 15° / 45°	± 10° ± 0.375" 15° / 45°	± 10° ± 0.375" 15° / 45°
Wire Feeder:	Integral, cable-mounted 5 - 100 IPM	On-board 5 - 100 IPM	On board 5 - 100 IPM	On board 5 - 100 IPM
Wire Spool Size:	2 lb., (4") standard spool	Low-profile standard 2 lb., (4") optional spool	2 lb., (4") standard spool	2 lb., (4") standard spool
Filler Wire Size:	0.030" or 0.035"	0.030" or 0.035"	0.030" or 0.035"	0.030" or 0.035"
Weight: (less cables)	11 lbs.	14 lbs.	16 lbs.	22 lbs.

ARC MACHINES, INC.®

AMI is an ISO Certified Company

www.arcmachines.com

HEADQUARTERS • Arc Machines, Inc. • 10500 Orbital Way, Pacoima, CA 91331 U.S.A. • Tel: 1-818-896-9556 • Fax: 1-818-890-3724

EUROPEAN OFFICE • Arc Machines, Inc. • Chemin du Lavasson 2, CH-1196 Gland, Switzerland • Tel: +41 / 22 / 995.00.51 • Fax: +41 / 22 / 995.00.59

GERMAN OFFICE • Arc Machines GmbH • Markelsbach 2 • D-53804 Much, Germany • Tel: 02245 / 91680 • Fax: 02245 / 916868

UK OFFICE • Arc Machines UK Limited • Unit 4, Raynesway Park Drive, Derby, UK, DE21 7BH • Tel: 01332 / 574000 • Fax: 01332 / 757757

sales@arcmachines.com

MKT 79 SERIES WH / JANUARY, 2008 / E

Arc Machines Inc., AMI and **AMI** are registered trademarks of Arc Machines, Inc.