

Thompson

INNOVATORS IN FRICTION WELDING



MODEL 125SE

Features and options

Computer storage for friction welding parameters

Consistent accuracy

Easy to automate

Flexibility to weld different components and metals

High production rates

Integrated flash removal

Integrated weld monitoring and archiving

Quick tool change

Single, dual or variable spindle speeds

MODEL 125SE



Model 125SE

Thompson's 125 single-ended friction welding machine is a popular model in the range and is suitable for welding large components. It utilises Thompson's unique software for in process weld monitoring and control.

Available in a sliding or fixed head format, the 125 SE is ideal for welding a variety of material combinations such as carbon steel, stainless steel, copper and aluminium.

Options include:

Turning or shearing flash removal

Angular alignment of parts

Computer interfacing for data handling

Thompson specialise in providing friction welding solutions and are the longest established supplier of friction welding equipment, boasting over 40 years' experience in developing advanced manufacturing processes for a wide variety of industrial components. The Thompson friction welding machine range offers forge capacities from 4 - 300 tons.



Technical Data		M8	M15	M50	M60	M80	M125	M250
Nominal forge load	tonnes	8	15	50	60	80	125	250
Nominal forge pressure	KN	80	150	500	600	800	1250	2500
Typical spindle power	KW	15	18	37	45	60	112	186
Range weldable (mild steel)	mm	4-25	8-36	20-70	25-75	35-90	50-125	65-150
Max Tube dia (mild steel)	mm	40	60	110	140	250	180	400
Max length in chuck	mm	150	450	600	600	600	750	1120
Max length in clamps	mm	-	-	-	-	-	-	-
Max weld area (mild steel)	mm ²	500	1000	4000	4500	6500	12500	18000

Machine Layout

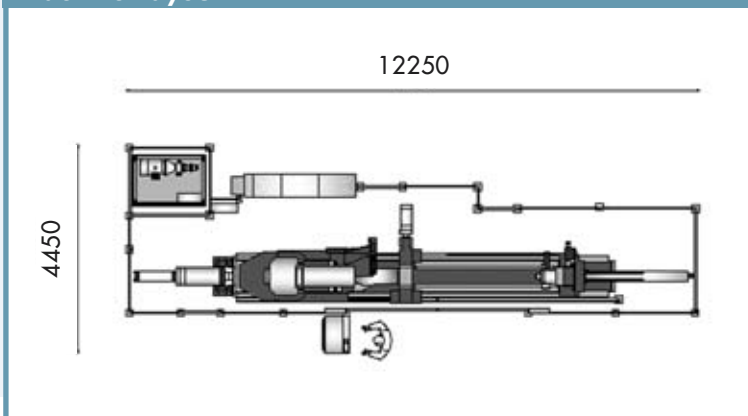

Thompson Friction Welding

Hereward Rise

Halesowen

West Midlands

B62 8AN

Tel: 0121 585 0888

Fax: 0121 585 0810

Email: sales@thompsonfw.co.uk

www.thompsonfw.co.uk

