

ID Mount Pipe Machining Equipment



**Beveling and Flange
Facing Equipment**



TRI TOOL INC.

Visit Tri Tool's website...
www.tritool.com
for the latest news and
product info!

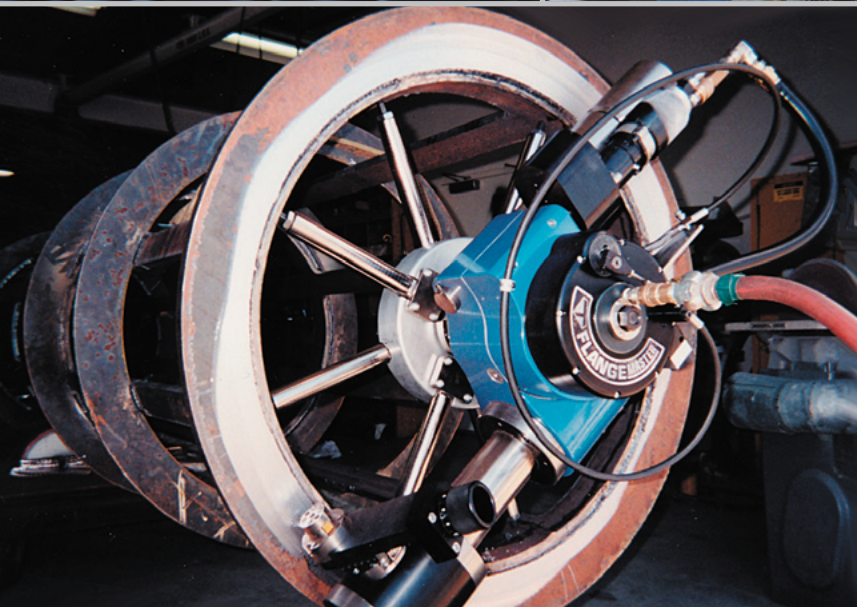
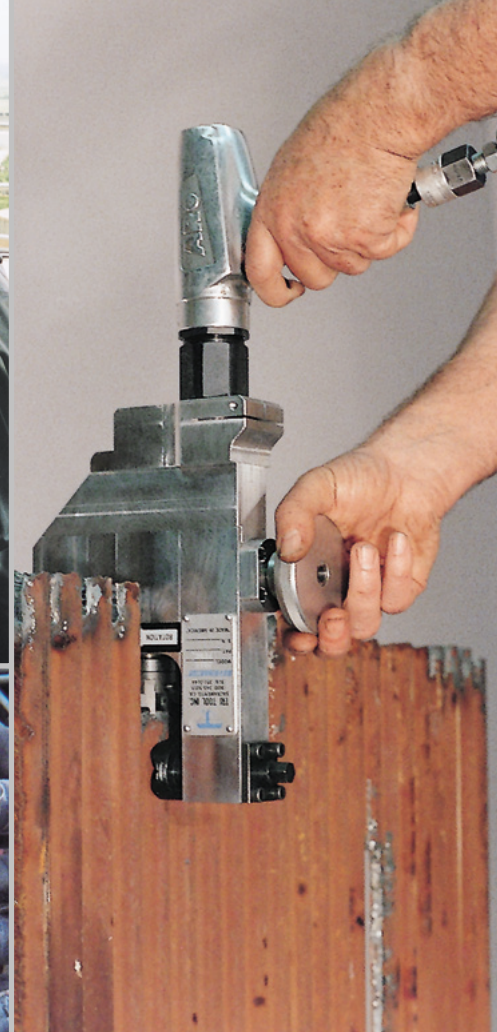
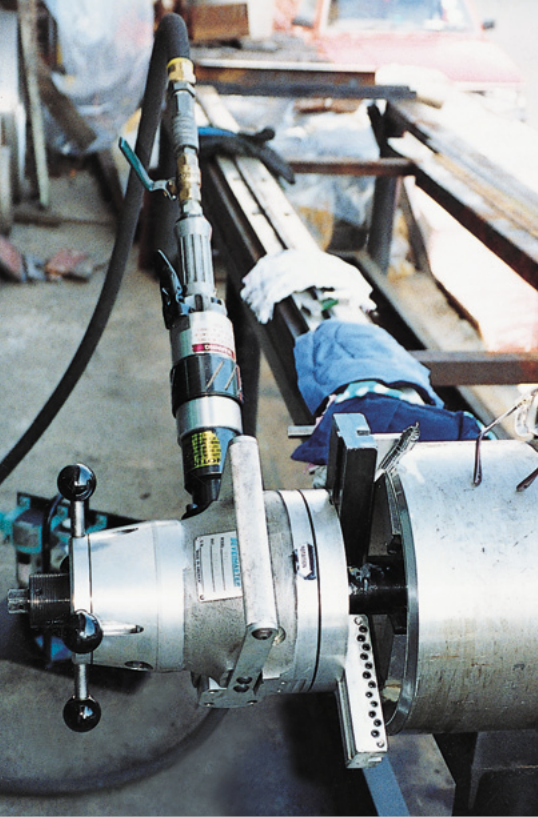

Tri Tool® portable ID mounted machine tools are being used throughout the world by companies who have learned to depend on their precision, performance, durability and ease of use.

The technically advanced industries of today use increasingly sophisticated piping systems. Inherent to these systems, is the requirement to modify, upgrade, extend and refit as needed. Scheduled pipe



and component replacement, new construction, and emergency repairs involving welded pipe, have become crucially important for successful plant operation. Economy mandates that the system downtime incurred in maintaining piping

systems be minimized for the least disruption of service. This factor, combined with the ever-increasing dependance on automatic orbital pipe welding equipment, has made the need for precision weld preparation an absolute necessity.

Tri Tool's portable weld preparation equipment answers these productivity and quality control issues by providing rapid and accurate weld preparation which in turn, helps to ensure superior welds in the least amount of time.

Tri Tool® portable equipment has been experience engineered for optimal performance. Whether being used for beveling, counterboring, flange facing or single point machining, the rugged machines produce accurate and repeatable end prep results. Supported by a wide range of optional accessories and advanced tool bit design, these versatile machines reduce the time it takes for necessary repairs and scheduled outages, providing cost-effective maintenance solutions.

A full line of reliable tube and pipe machining tools guarantee that Tri Tool Inc. has exactly the right equipment solutions to satisfy your specific job requirements.

Visit our Internet web site (www.tritool.com) or contact our customer service representatives to discover how to save time and money on your next project with quality Tri Tool® portable equipment.

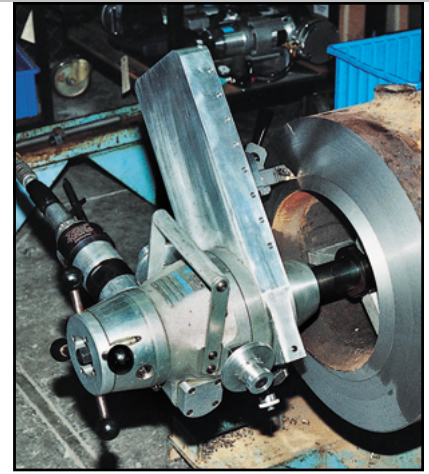

Solution Profile: The ability to efficiently generate dependable, high precision tube and pipe weld preparation by means of an easy-to-use portable machine tool which clamps into the pipe ID, is an extremely important advantage for many industries.

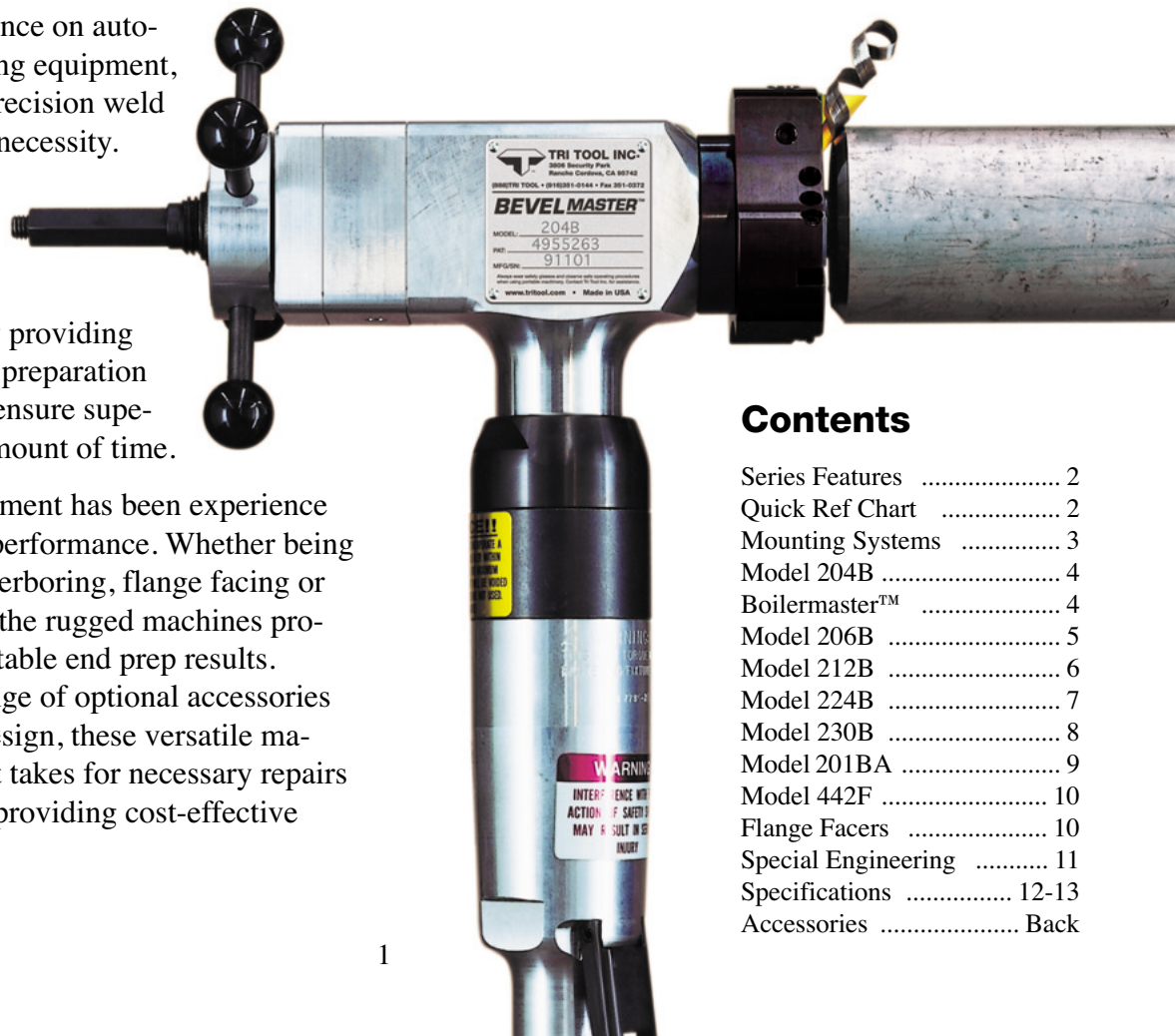

Contents

Series Features 2
 Quick Ref Chart 2
 Mounting Systems 3
 Model 204B 4
 Boilermaster™ 4
 Model 206B 5
 Model 212B 6
 Model 224B 7
 Model 230B 8
 Model 201BA 9
 Model 442F 10
 Flange Facers 10
 Special Engineering 11
 Specifications 12-13
 Accessories Back

Equipment Features

ID mounted tools offer a rapid and dependable method for on-site weld end preparation, flange facing, and other special machining operations.

Tri Tool® ID mounted end prep equipment utilizes an expandable, self-centering mandrel system which mounts in the open end of a tube or pipe. Jaw blocks, corresponding to the size of pipe being worked on are placed on the mandrel. When a draw rod is tightened, jaw block bases are drawn up an inclined ramp, expanding the jaw blocks against the inside bore of the pipe. This provides a solid, torque accepting grip for accurate machining operations.

Some tools can be fitted with optional cutting heads which expand the cutting range to cut larger pipes or perform special additional machining operations.

For machining fittings, an elbow mandrel is available that uses expanding pins to provide positive mounting in a short depth, just inside the pipe or fitting bore. Miter mandrels angle the machine to produce a precision bevel in a plane which is not perpendicular to the center line of the pipe.

Special full contact mandrels are available which do not mar the bore while countering out-of-round conditions, perfect for thin wall pipe. For out-of-round pipe, tracking modules may be used to prep the end of the pipe with a bevel that is uniform to the ID bore. Special flange facing modules are available for some beveling tools to restore the surface of damaged or worn flange sealing faces.

Single point machining accessories provide fully adjustable bevel angle machining capabilities. Unlike form tooling where the desired cutting angles are ground into the bit and then transferred to the pipe, single point machining can provide any complex weld prep profile within their cutting range. This capability provides an invaluable means for accurate weld prep machining to meet the most demanding specifications and allows the machinery to perform reliably on the widest range of pipe materials and alloys. Power for the machines is provided by a variety of dependable sources.

Tri Tool® machinery delivers maximum performance, flexibility, and cutting options. If your pipe requirements are outside the range of standard equipment or you are dealing with a special material or environment, our customer service representatives will assist you with special equipment solutions for your specific application.

200 Series Quick Reference Chart

● Standard
○ Special Order

Model	Mounting Range ¹		Optional Mandrels	Optional Head Kits	Elbow Saddle Kits	Miter Mandrel	Sleeve Mandrel	ID Tracking Mandrel	Flange Facing Module	Single Point Module	Pneumatic Drive	Electric Drive	HD Electric Drive	Hydraulic Drive	Lift Type
	ID	OD													
201BA (OD Mount)	N/A ²	2.0" 50.8 mm	●	●						●	○				Handheld
204B	.610" 15.49 mm	4.5" 114.3 mm	●		●			○	●	●	●				Handheld
BOILERMASTER™	.610" 15.49 mm	4.5" 114.3 mm	●	●						●					Handheld
206B	1.625" 41.28 mm	6.625" 168.28 mm	●		●	●	●	●	●	●	●	○			Handheld
212B	3.44" 87.4 mm	24.0" 609.6 mm	●		●	●	●	●	● ³	●	●	○	○		Handheld
224B	6.813" 173.0 mm	24.0" 609.6 mm				●		●	● ³	●	●		●		Removable Lifting Frame
230B	11.13" 282.7 mm	60.0" 1524 mm	○			○	○ ⁴	○	○	○			●		Removable Lifting Frame

1. Determine the pipe ID's for the schedule of pipe you work with to determine mounting range needed. 2. Not applicable for this model (OD mounted).
3. Dedicated flange facing module, single point module can also perform flange facing. 4. Full support ID mandrel shoes are used for large pipe with these models.

Mounting Methods

Whether you are working on pipe, tees, elbows, or doing mitered cuts, Tri Tool has reliable mounting systems for you.

The illustrations below show the four basic mounting systems employed by Tri Tool® ID mounted equipment to provide secure positioning for precision beveling or machining. Specialized mounting systems can be provided, in addition to those shown, to perform specific cuts or for unique machining operations.



Solution Profile: An elbow mandrel head being mounted in a fitting and being aligned with a dial indicator for maximum precision.

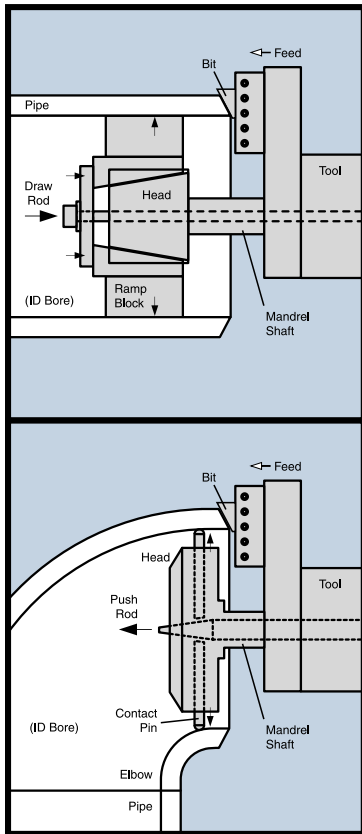

(Std) Mandrel

The standard ID mandrel works on the simple principal of tightening a threaded draw rod that pulls an end plate. The end plate drives several blocks up ramps, expanding the ramp blocks into the ID bore. This locates the tool both centered and square to the run of pipe.

Elbow Mandrel

Where the curves of a tee or elbow prevent the use of ramp blocks, an elbow mandrel grips the fitting by means of a series of contact pins. The pins slide in and out from the center of the head. A threaded push rod with a tapered end presses the pins outward for engagement with the ID bore.

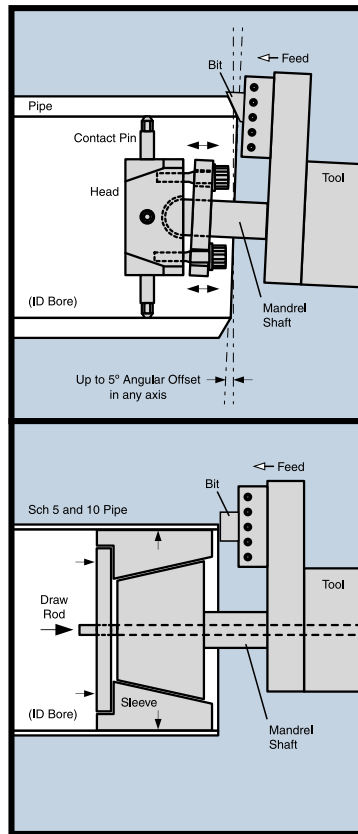

Miter Mandrel

Miter mandrels compensate for misalignment, or are used in irregular openings. Individual, threaded contact pins center and secure the head. A ball & socket system with bolts on the face of the head adjust angular offset up to 5° in all directions.

Sleeve Mandrel

The nylon sleeve mandrel is used to protect thin wall pipe from marring. A full-contact expanding sleeve is pressed against the bore by tightening a threaded rod. The rod draws back on an endplate, pulling the sleeve against a tapered core, simultaneously rounding the pipe.

Single Point Kits

Single point machining allows more flexibility of cut for complex machining operations and compound bevel angles.

Portable beveling machinery produces bevel angles primarily through the use of form tool bits that have angled cutting edges. Form tool bits can only generate bevel angles predetermined by their cutting surface. Single point machining utilizes generic cutting bits that produce bevels based on the feed angle, and direction of the bit holder. This permits the production of basic as well as compound bevel profiles with the same bit.

Single point kits have been designed to provide extended cutting capabilities for the Model 212B, 224B, and 230B. This means you can perform a much wider variety of end uses with the same equipment without the need to buy additional tools.

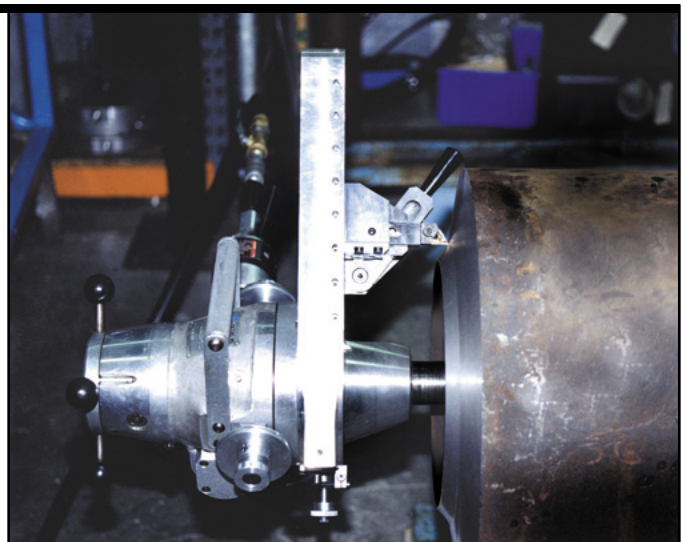

Solution Profile: The versatile Model 212B BEVELMASTER™ with Single Point module generating a precision compound bevel on heavy wall pipe.

BOILERMASTER™

The Boilermaker's Workhorse

- Wedge Lock Bits
- Rugged Tool Steel Mandrel
- Mandrel Shaft Seal
- Ratchet Feed System
- 1.5 HP Drive Motor
- Optional Cutting Head

The BOILERMASTER™ is specially designed for boiler machining where its right-angle feed is perfect for working in confined spaces. It features a powerful 1.5 HP motor and its compact cutting head accepts standard and wedge-lock bits for heavy-duty use. A sealed head protects inner components and the milled body houses heavy duty gears with tapered roller bearings for reliability. The tool steel mandrel and durable hardened steel mounting blocks provide maximum grip on water walls and pipes making this machine the best choice for boiler construction and maintenance.



Solution Profile: The rugged BOILERMASTER™ being used to rapidly face header stubs which had been torch cut.



Model 204B

Portable
Versatility

BEVELMASTER™



The Model 204B features in-line feed and a cutting head that accepts various bits. The 1.5" feed length is perfect for deep counterboring and the body has mounting holes for additional accessories.

- In-line Feed
- Flange Facing
- Optional Mandrels
- 1.5 HP Motor

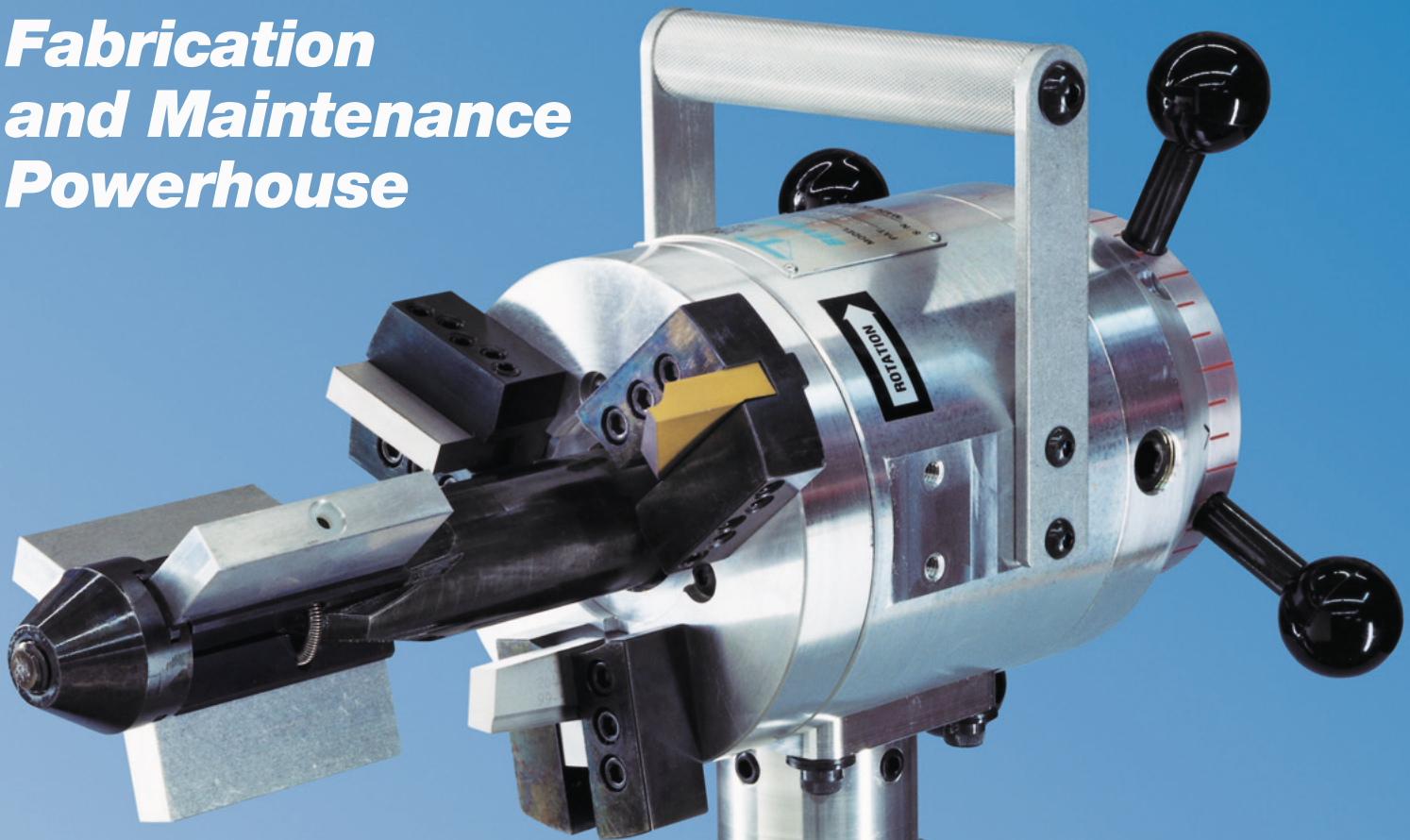
Model 206B***BEVEL MASTER™******Fabrication
and Maintenance
Powerhouse***

- **Bevel, Face & Counterbore**
- **Flange Facing Operations**
- **Elbow and Miter Mandrels**
- **Sleeve Mandrel for Thin Wall**
- **A Wide Range of Special Accessories**

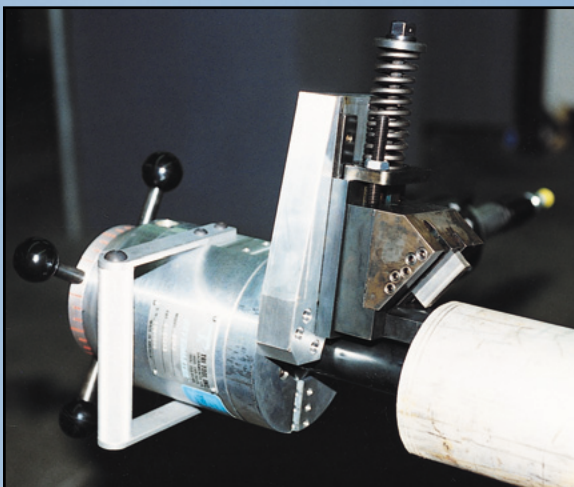

Solution Profile: A Model 206B BEVELMASTER™ fitted with a ID tracking module ready to perform a standard bevel.

The extremely rugged and powerful Model 206B has the features you need for dependable weld preps. The machine is rigid, lightweight, and utilizes adjustable torque keys that compensate for wear, eliminating slop and vibration and producing smoother cuts. Elbow mandrel, miter mandrel, and flange facing modules extend machining capabilities. The design of the Model 206B permits an unobstructed view of machining operations. Facing, beveling and counterboring can be performed simultaneously. A 3HP motor and smooth roller bearings make the Model 206B BEVELMASTER™ the true industry powerhouse.

Model 212B

**Proven
Midrange
Reliability**

BEVELMASTER™



- Pneumatic, Hydraulic or Electric Drive
- Single Point Module
- Form Tool or Carbide Insert Cutting
- Versatile Mounting Options



Solution Profile: The handy Model 212B BEVELMASTER™ on the job performing a weld preparation bevel on stainless steel pipe.

The Model 212B BEVELMASTER provides a wide working size range with a single standard mandrel. The open design of the tool holders allows for full viewing of machining operations for simultaneous facing, beveling and counterboring. Torque key adjustment on the mandrel prevents backlash and vibration, providing smoother cutting. A double enveloping worm gear set is used for maximum strength and machine life.

Model 224B

The Ultimate Heavy-Duty Beveling Platform

- Single Point Kit for Beveling up to 42" and Flange Facing up to 50"
- Removable Stand/Lifting Frame
- Quick Change 2 Speed Gearbox
- ID Tracking Module Kit and Miter Mandrel Kit
- Preloaded Ball Bearing Design Provides Quiet Precision
- Heavy Duty Stand & Lifting Ring

Tri Tool's new Model 224B BEVELMASTER™ is the premier machine available in the industry for beveling, facing and/or counterboring 8" through 24" pipe, and counterboring IDs greater than 8.5 inch. This machine comes configured with an in-line feed control, precision laser-etched feed increments, and new style grip handles that reduce operator fatigue. The incredibly smooth action has power to spare thanks to a strong pneumatic drive



Solution Profile: Tooling extensions permit increased capacity for larger applications.

motor mounted at a right angle to the lathe head. The innovative two speed gearbox enables you to select the optimum gear ratio for the work at hand. Three rugged integrated tooling arms allow for simultaneous machining operations with exceptional precision. The machine is

BEVELMASTER™



finished in durable powder coating, anodization and nickel plating to resist the corrosion of harsh environments and allowing easier clean-up and maintenance. The Model 224B BEVELMASTER™ system comes complete with (3) tool holder assy., mandrel assy., mandrel head assy. (3 jaw), and upper lifting frame (w/ optional floor stand), ready to tackle the worst jobs you're confronted with.

This feature-packed machine is the new standard that all other bevelers will be measured against. Call today to discover how the 224B can satisfy your most demanding requirements.

Model 230B**Maximum
Beveling
Power****BEVELMASTER™**

- **Rigid Form Tool or Single Point Machining**
- **ID Tracking Module**
- **Dual Drives**
- **Elbow & Flange Mounting**

The strong, stable Model 230B BEVELMASTER™ platform provides unique ID mounted machining capabilities for heavy duty weld preparation on 14" to 60" pipe. The powerful ID mandrel shaft provides superior mounting strength and support which allows rapid setup and a strong, torque-accepting grip. A gear reduction unit on the feed system and adjustable tool

modules combine with handy in-line feed knobs for ease of use. Single or dual hydraulic motors with a rugged worm drive system provide maximum power for single point, form tool, and miter cutting. An optional ID tracking system provides precise weld preparation on out-of-round pipe.

Model 201BA

Note: This is the only 200 Series machine which is OD mounted.

BEVELMASTER™

Waterwall Solutions



Solution Profile: The slim profile and handy controls of the Model 201BA BEVELMASTER™.

- Optional Cutting Heads
- Thin Design for Cut-out Windows
- Adjustable Clamping

The lightweight, compact design and small diameter bolt-on cutting head of the Model 201BA BEVELMASTER™ allow it to perform rapid, accurate machining in tight spaces, making it perfect for boiler use. The OD mounting – no mandrel design (clamps to the outside of tube or pipe) allows this machine to successfully work on boiler tubes with inside diameters under 1" with less damage than ID mounting with a mandrel system. The machine provides rapid clamping saddle adjustments and a right angle feed knob with all controls (feed, clamp, motor) on the outside of the tube panel opening for safe and easy operation. The narrow width of only 1.45" permits use on waterwall cutout windows and between boiler panels. The Model 201BA's two adjustable saddles cover the full cutting size range.

Model 442F

FLANGEMASTER™

Power and Precision

NEW!

- **3 Way Autofeed System:** Integrated lead screw feeds the bar, the carriage, or the compound slide
- **Fully adjustable slide** permits boring, turning, and facing
- **Unique mounting system** provides precision centering and alignment
- **Backlash Regulator:** Preloaded braking system provides smooth performance through interrupted cuts
- **Quick-change dual-speed gearbox** delivers optimum cutting speeds
- **Strong, reversible motor with worm drive**
- **Counter Balanced** for consistent cutting speed - uphill and downhill
- **Tapered bushings** adjust to zero clearance for maximum rigidity.

The rugged Model 442F has been designed to machines perfect sealing surfaces on flanges ranging from 14" (355.6mm) ID through 42" (1066.8mm) OD. The machining range can be extended (with an optional extension kit) to 73.0" (1854.2mm) OD to handle your largest flanges with ease.

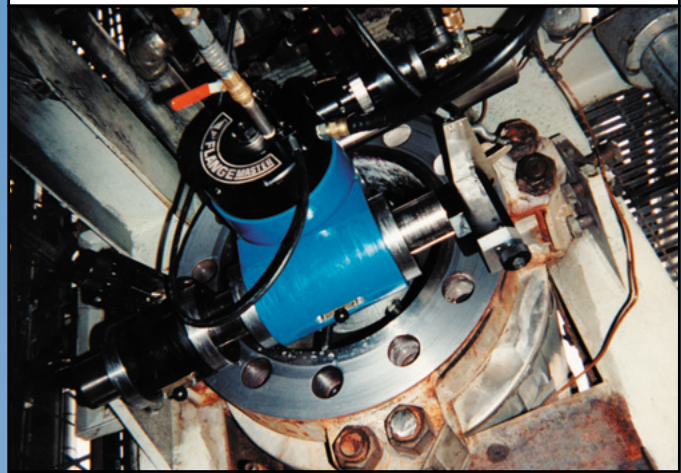
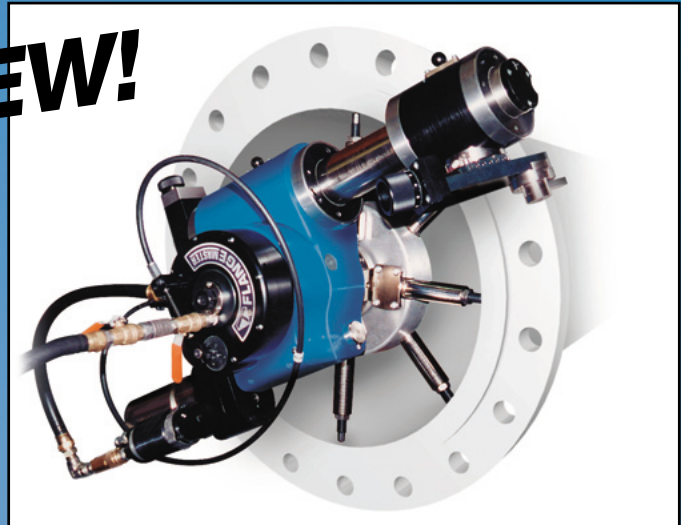

Solution Profile: A new, Model 442F FLANGEMASTER™ with standard arms performing a facing operation in a reduced clearance situation.

Flange Facing Kits

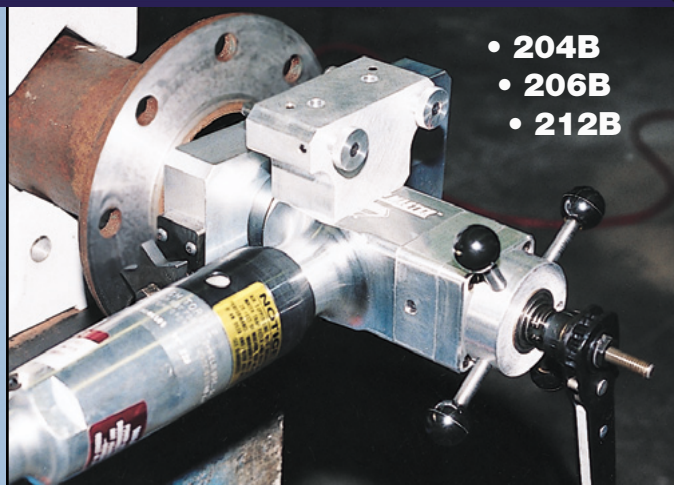

- **204B**
- **206B**
- **212B**

Solution Profile: The versatile Model 204B BEVELMASTER™ with Flange Facing Kit performing double duty as a precision flange facer.

Quickly and easily resurface damaged flat and raised faced flanges in-place.

The Flange Facing Kits for the Models 204B, 206B, and 212B are designed to allow these proven portable beveling tools to be converted to dedicated flange facers. The kits come factory configured or can be retrofit to a customer's existing tool. The kit is comprised of the facing attachment, a dual tripper-pin assembly and an elbow mandrel assembly. The kits feature dual feed rates and work with our tooling to generate a variety of precision surface finishes.

Note: The standard mandrel and beveling toolbit holders are not included when machinery is configured as a flange facer by the factory.

Special Engineering

Even though Tri Tool manufactures a wide range of standard ID mounted tools and accessories, special engineering, design and custom manufacturing can still be necessary for some jobs.

Companies have learned to depend on Tri Tool's special engineering services for straightforward and economical solutions to complex pipe cutting requirements. Whether it is a unique environmental problem such as pipe cutting in nuclear power plants where remote operation is a must, or cutting where space limitations preclude the use of typical machines or accessories, Tri Tool provides equipment support through the modification of existing products or with completely custom tools. Extensive design experience and state-of-the-art computer design capabilities allow Tri Tool to provide superior equipment of uncompromising strength and performance.



Solution Profile: When it comes to completely custom pipe cutting machinery, customers depend on Tri Tool's special engineering as was the case with this ID mounted saw which cut from the bore out.

using special materials or coatings to provide for ease of decontamination, prevent corrosion or prevent foreign material contamination of exotic pipe alloys.

Automation - Often customers require machinery which has been set-up for high volume or automated production through the use of special base plates, fixtures, feed assemblies, indicators, and tool bit holders. Machinery has been manufactured with automatic feed and shut-off features to increase production and consistency.



Clamping - Custom designs can provide special clamping or mounting of cutting tools for thin, odd sized and difficult mounting conditions where standard mounting methods can not be used.

Materials - Parts, accessories, or entire machines may be manufactured using

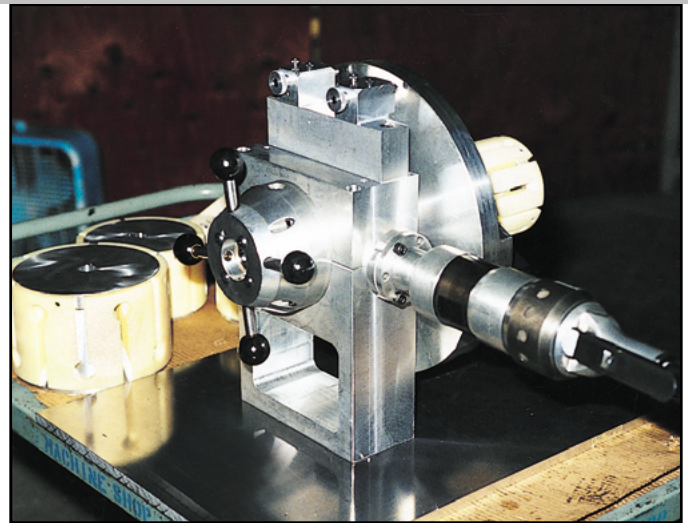

Solution Profile: A Model 206B set up for high volume thin wall tubing production with optional sleeve mandrel sizes, a bench stand, and dual tripper assemblies for rapid cutting.

Remote Operation - ID mounted equipment can be controlled by special remote consoles or control pendants, allowing the operator to safely and effectively control machining operations in hazardous or space restricted situations. Video cameras and lights can be mounted to allow remote viewing of the procedures or for recording.

No matter what your needs are, from a custom tool bit to a complete machine design, Tri Tool's engineering, production, R&D, assembly, and quality assurance personnel are committed to delivering special machinery to you with the same attention to detail, ease-of-use and quality our customers have come to expect. Contact your sales representative for more information about special engineering services.

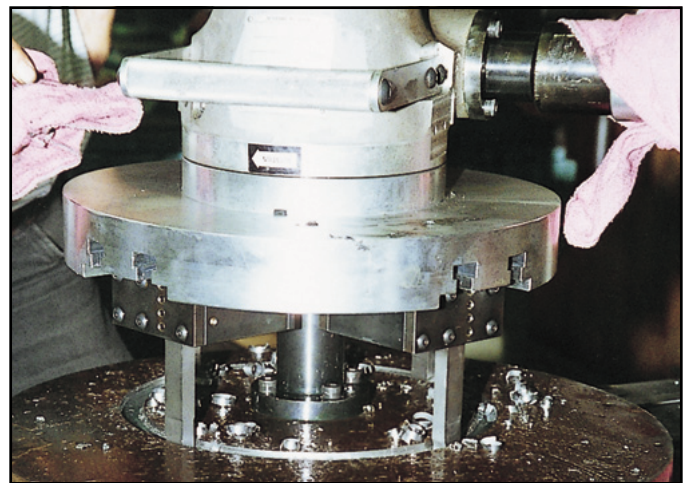

Solution Profile: With its power and solid mounting characteristics, the Model 212B BEVELMASTER was perfectly suited for this four cutting bit trepanning operation being tested here. Note the specially designed bolt-on style mandrel which precisely locates the machine to the work

Specifications

Model 204B BEVELMASTER™

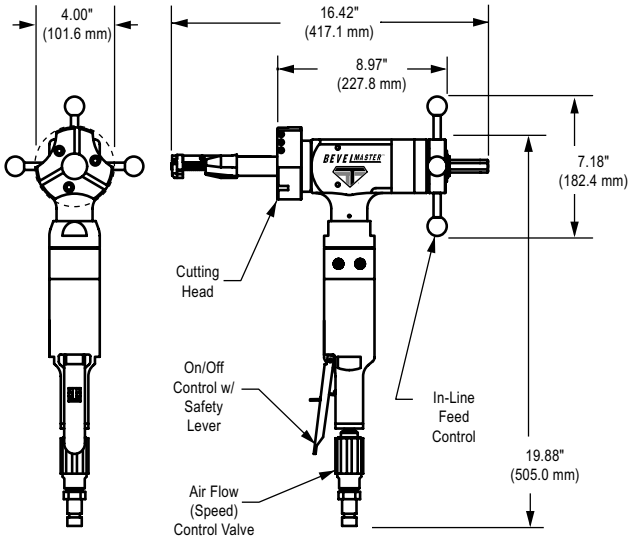

BOILERMASTER™

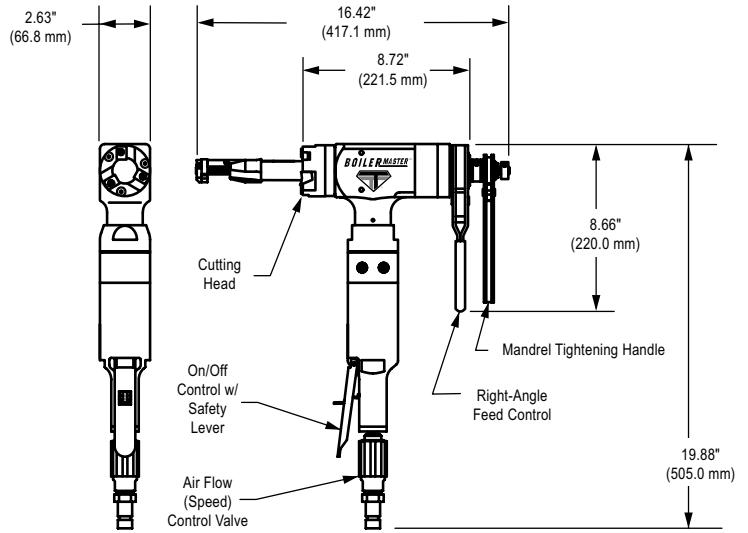

	Pipe size Min - Max	Tube Size Min ID - Max OD	Max Wall Capacity	Feed Travel	Weight	Absolute Mounting Range ID - OD
Model 204B	1 1/4" (33.4 mm) - 4" (114.3 mm)	.610" (15.49 mm) - 4.5" (114.3 mm)	.531" (13.5 mm)	1.50" (38.1 mm)	19.5 lbs. (8.86 Kg)	ID .610" (15.49 mm) - OD 4.5" (114.3 mm)
BOILERMASTER*	1 1/4" (33.4 mm) - 4" (114.3 mm)	.610" (15.49 mm) - 4.5" (114.3 mm)	.531" (13.5 mm)	1.50" (38.1 mm)	18 lbs. (8.16 Kg)	ID .610" (15.49 mm) - OD 4.5" (114.3 mm)

*The BOILERMASTER™ is configured with features most desirable for use in boilers on water walls and headers, whereas the 204B BEVELMASTER™ is configured for general purpose pipe beveling. A full complement of optional accessories are available for each model.

Model 206B BEVELMASTER™

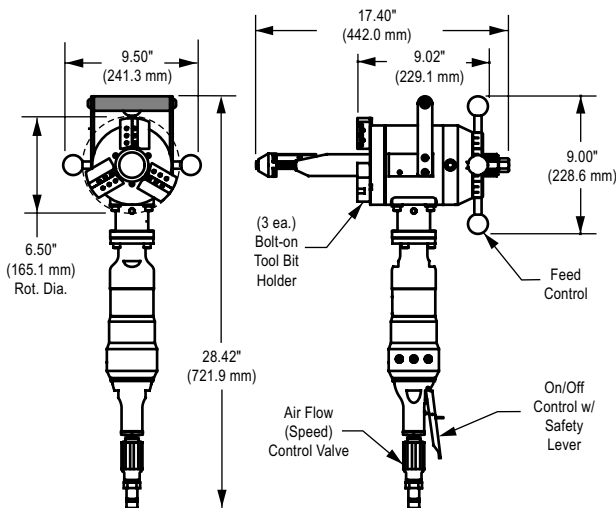

Model 212B BEVELMASTER™

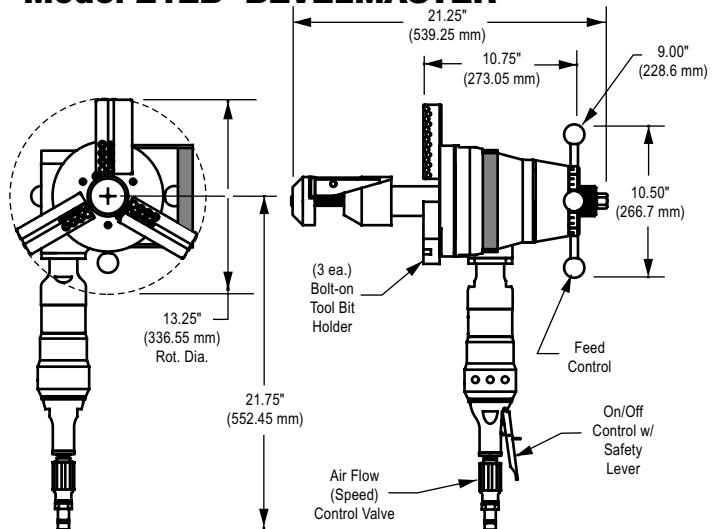

	Pipe size Min - Max	Tube Size Min ID - Max OD	Max Wall Capacity	Feed Travel	Weight	Absolute Mounting Range
Model 206B	2" (60.3 mm) - 6" (168.3 mm)	1.63" (x 41.4) - 6.63" (168.4 mm)	.875" (22.2 mm)	2" (x 50.8)	50 lbs. (22.7 Kg)	ID 1.63" (41.4 mm) - OD 6.63" (168.4 mm)
Model 212B	4" (114.3 mm) - 12" (323.8 mm)	3.44" (87.37 mm) - 12.75" (323.85 mm)	1.315" (33.40 mm)	2" (x 50.8)	80 lbs. (36.3 Kg)	ID 3.438" (87.32 mm) - OD 12.75" (323.85 mm)

THIS INFORMATION IS PROVIDED AS A GUIDELINE ONLY TO ASSIST WITH THE SELECTION OF EQUIPMENT AND ACCESSORIES. THIS INFORMATION IS SUBJECT TO CHANGE WITHOUT NOTICE. CONTACT YOUR SALES REPRESENTATIVE FOR SPECIFIC DETAILS OR TECHNICAL SPECIFICATIONS.

Model 224B BEVELMASTER™

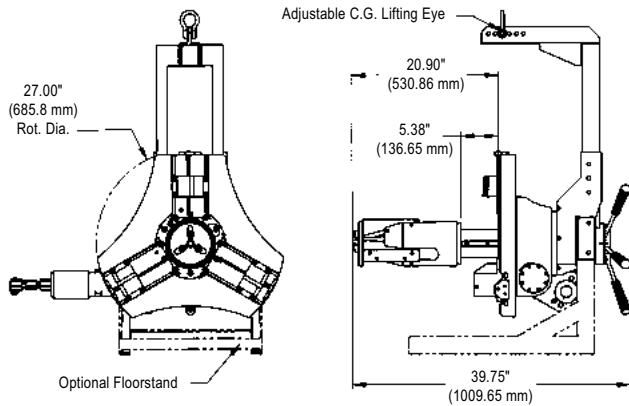

Model 230B BEVELMASTER™

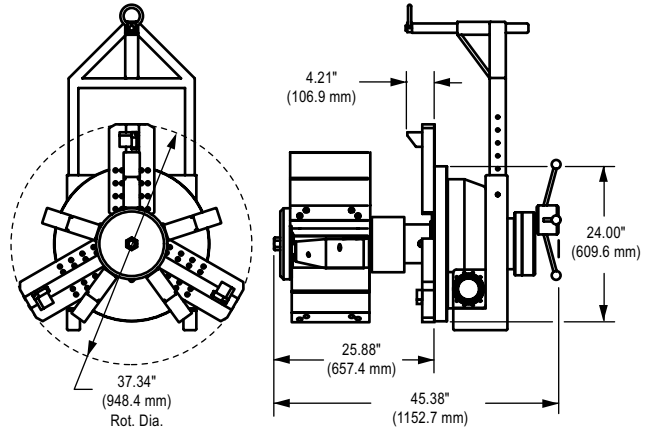

	Pipe size Min - Max	Tube Size Min ID - Max OD	Max Wall Capacity	Feed Travel	Weight	Absolute Mounting Range
Model 224B	8" (219 mm) - 24" (609.6 mm)	6.813" (173 mm) ¹ - 24.0" (609.6 mm) ²	2.34" (59.4 mm)	5.38" (136.6 mm)	420 lbs. (190 Kg)	6.813" (173 mm) ¹ - 24" (609.6 mm) ²
Model 230B	14" (355.6 mm) - 30" (762.0 mm) ³	11.13" (282.78 mm) ¹ - 30.0" (762.0 mm) ²	2.34" (59.4 mm)	4.0" (101.6 mm)	900 lbs. (408.2 Kg)	11.13" (282.7 mm) ¹ - 30" (762.0 mm) ²
Model 201BA²	.25" (13.71mm) - 2" (60.32 mm)	.25" (6.35 mm) ² - 2.0" (50.8 mm) ²	4.00" (10.16 mm)	.75" (19.05 mm)	15 lbs. (6.8 Kg)	.25" (6.35 mm) ² - 2.0" (50.8 mm) ²
Model 442F	For Flange Dia. 14" (355.6 mm) up to 73" (1854.2 mm) with extension kit. ⁵		N/A	Variable Speed	404 lbs. (183.2 Kg) ⁶	.14" (355.6 mm) ¹ - 72" (1828.8 mm) ¹

¹ID, ²OD, ³Single Point Module extends range to 60" (1524 mm), ⁴Single Point Module extends range to 30" (762 mm), ⁵Up to 42" (1066 mm) with standard machine, ⁶Standard machine configuration.

Model 201BA BEVELMASTER™

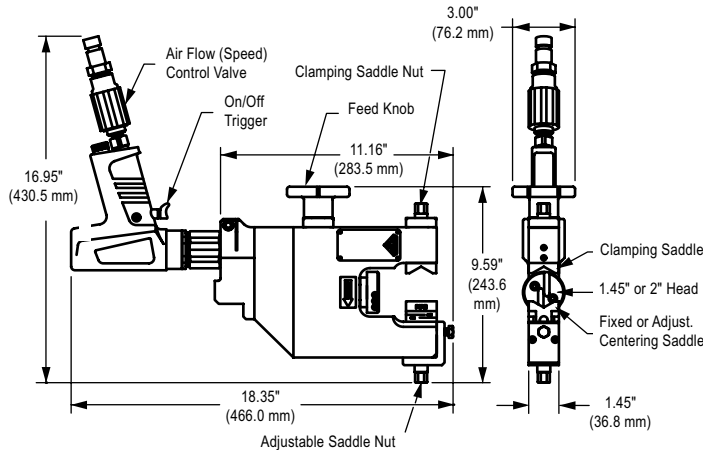

Model 442F FLANGEMASTER™

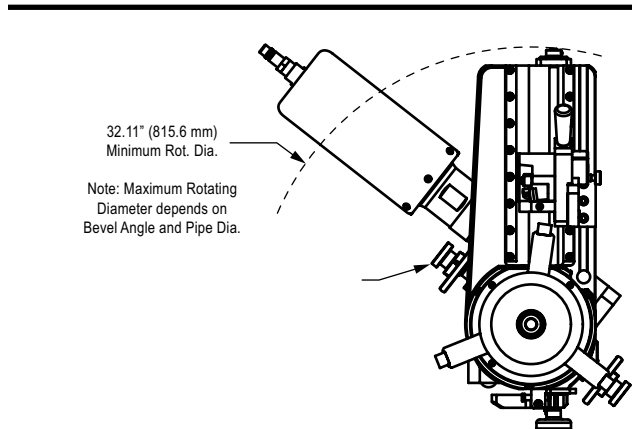
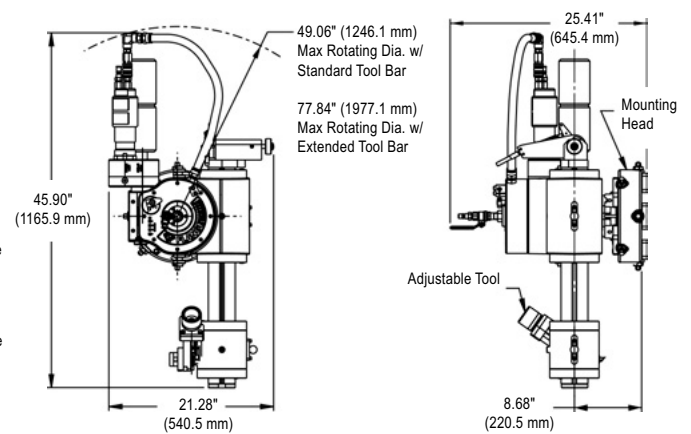

Single Point Module

(Shown mounted on a Model 212B BEVELMASTER™)

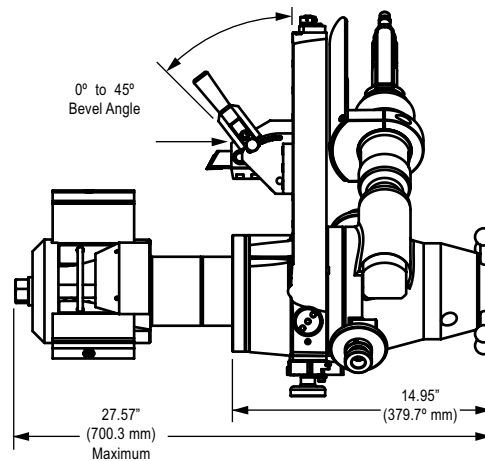

	Pipe size Min - Max	Tube Size Min ID - Max OD	Max Wall Capacity	Feed Travel	Weight	Absolute Mounting Range
Model 212B w/ Single Point	10.0" (254.0 mm) - 24" (609.6 mm) ¹	8.20" (208.3 mm) - 24" (609.6 mm)	Variable ²	Variable ²	170 lbs. (77.27 Kg) ³	6.10" (154.9 mm) - 23.50" (596.9 mm)

1. Minimum cutting diameter is 8.20" (208.3 mm), though machine will mount down to 6.10" (154.9 mm). 2. Depends on prep geometry: 1.50" (38.1 mm) @ 37.5° to 8.0" (203.2 mm) for facing. 3. Machine weight including 212B, Single point module, and 3-jaw mandrel.

Accessories

Cutting Head Kits - Optional cutting heads can be used with some machines to increase the weld preparation range –smaller for working in areas of low clearance or larger for fabrication applications.

Mandrels and Jaw Blocks - All models within the 200 series use torque accepting mandrels with a variety of jaw block combinations to produce accurate and solid mounting into the widest range of tube and pipe sizes. Jaw blocks are produced in various materials to conform to your machining requirements and applications where dissimilar contamination is a concern.

ID Tracking Modules - Innovative ID Tracking modules are available for some equipment models which compensate for minor shape variations and out-of-round conditions of a pipe end by utilizing a wheel which tracks the irregular shape, maintaining a consistent cut.

Hydraulic, Pneumatic, and Electric Drive - Powerful hydraulic drive motors are available for use with some equipment for maximum power and performance depending on your applications. Dependable air driven motors are available on all models. Electric motors are also available for some machines to provide clean, smooth power.

Carrying Cases - Durable, custom fit carrying foam lined carrying cases are available to protect your ID mount equipment for storage or shipping. Cases contain recesses for bits, blocks, special tools, and accessories, depending on the equipment model.

EXTENDED CAPABILITIES

Hydraulic Power Supplies - 15 HP Hydraulic pumps deliver 1800 psi @ 22 GPM, ideally suited for situations requiring maximum power and speed flexibility.

Pneumatic Air Lubricators - (Below) Pneumatic lubricators (Caddies) are required for use with Tri Tool® pneumatic tools to properly lubricate the air mechanism, protect the warranty, ensure longer equipment life and maximize performance.



Tri Tool® Equipment

A WIDE RANGE OF SOLUTIONS

BEVELING MACHINES

Powerful and easy to setup and operate, the 200 Series BEVELMASTER™ and the BOILERMASTER™ machines deliver excellent ID mounted pipe beveling performance for portable weld end preparation on 1.25" to 30" pipe. With a wide range of optional attachments, you can perform in-place flange facing, counterboring, mount in elbows, or prep thin wall tubing.



IN-LINE SEVER/BEVEL

The "Clamshell" lathe can be separated and reassembled to mount to the OD on in-line or open ended pipe to produce dependable severing and beveling. These versatile and reliable lathes can be fitted with optional single-point machining equipment to provide complex compound bevels, "J" preps, and counterbores. Clamshell lathes are available from 1" to 60" and can be configured or modified for specific cutting operations.



ON-SITE MACHINING

Tri Tool's service division has field machining technicians with the experience and equipment to reliably and economically provide you with the most on-site machining options. Convenient equipment rental programs ensure you get reliable Tri Tool® machinery when you need it, for scheduled maintenance, emergency repairs, or any specific machining operation.



TUBE SEVER/SQUARE

The 300 Series squaring and 500 Series severing machines rapidly and easily produce extremely accurate severing and weld end preparation on .125" to 8" tube and pipe. These precision portable machines are the perfect companions to automatic orbital welding equipment for tube production, or for the construction and maintenance of high purity welded tubing systems.



Save time and money with dependable TRI TOOL® portable machining equipment!



TRI TOOL INC.

3041 Sunrise Blvd. • Rancho Cordova, CA 95742
(800)-345-5015 • (916) 288-6100 • Fax (916) 288-6160
customer.service@tritool.com • www.tritool.com

**Tri Tool® machines
are offered for
sale or rental.**

© Copyright Tri Tool Inc. All rights reserved.
Printed in the USA PN 81-0039 (03-00)